

— Outline
 — Dimension
 — Blocks

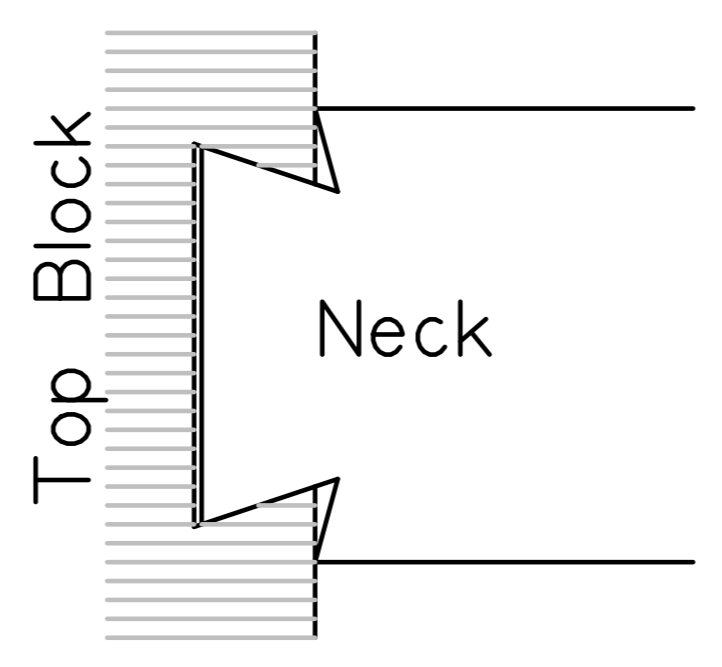

Neck Joint

A dovetail neck joint is shown, but you could replace it with a joint of your choice. A dovetail joint does not use the entire depth of the cavity provided by the body. There is a small gap which ensures that the joint sides are well fitted. Similarly, a small gap between the inner neck and body will ensure a tight fit between the body and outer neck. The joint tapers from wide near to the soundboard, to narrow near to the back. This type of joint is extremely strong and resists movement over time.

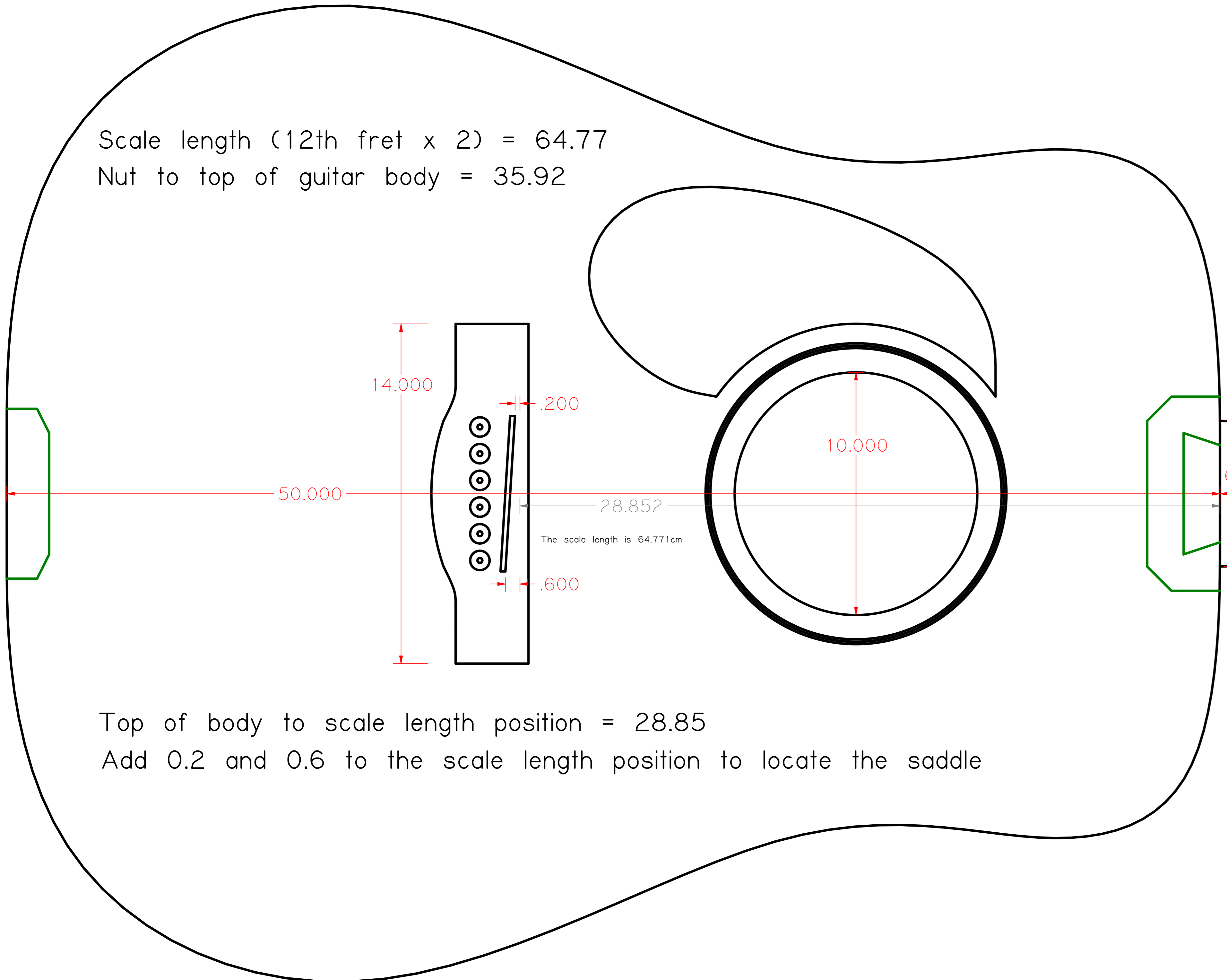
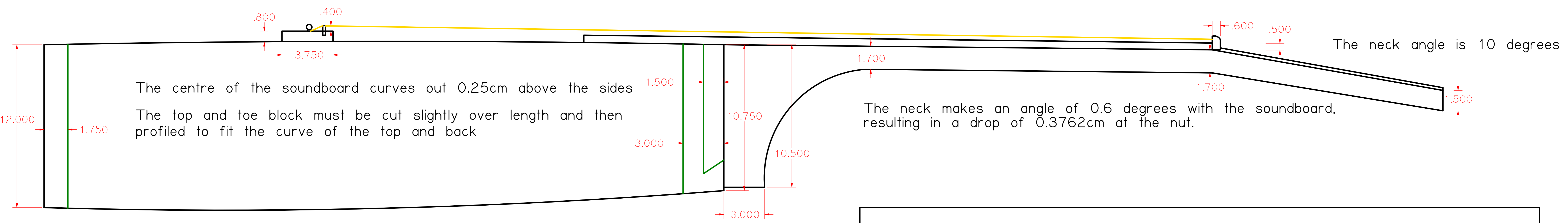
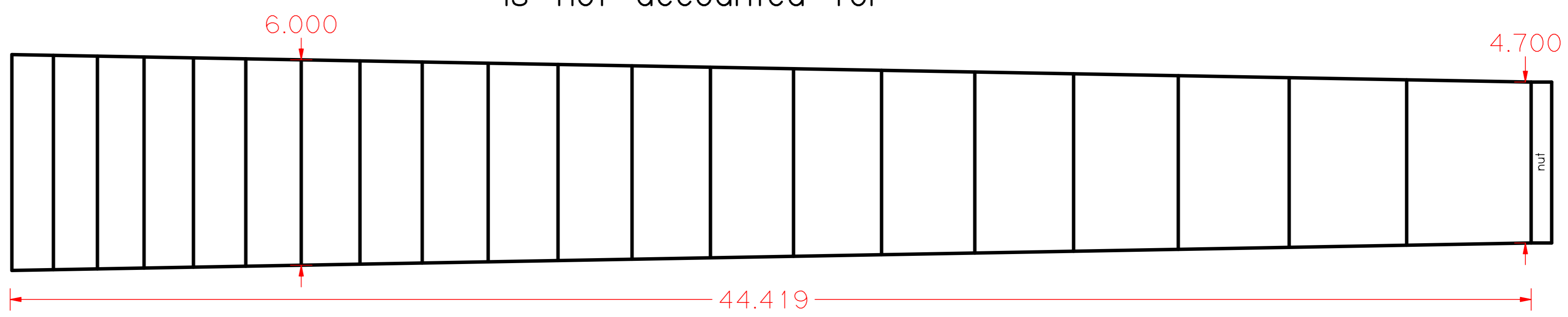
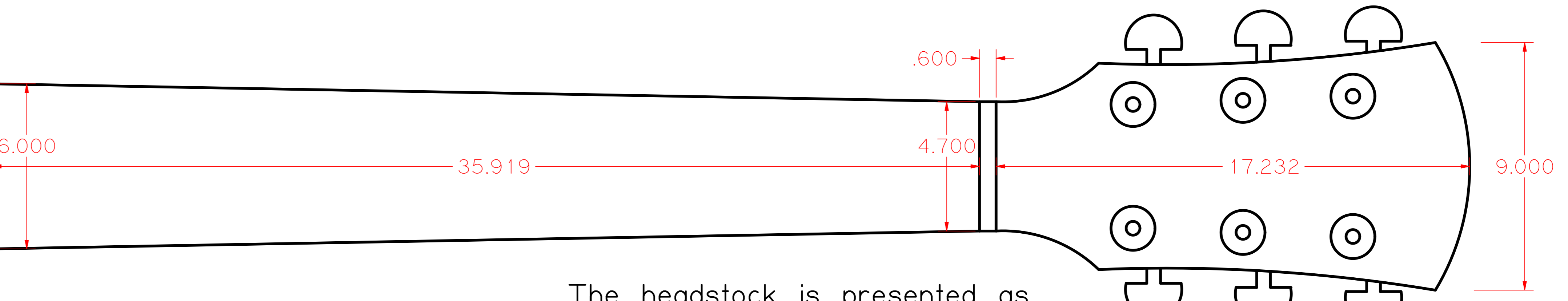

Fret No.	Distance from nut	Fret No.	Distance from nut
1st	3.6353	10th	28.4193
2nd	7.0665	11th	30.4595
3rd	10.3052	12th	32.3852
4th	13.3621	13th	34.2028
5th	16.2474	14th	35.9185
6th	18.9708	15th	37.5378
7th	21.5414	16th	39.0662
8th	23.9676	17th	40.5089
9th	26.2577	18th	41.8706
		19th	43.1558

The scale length is 64.771cm

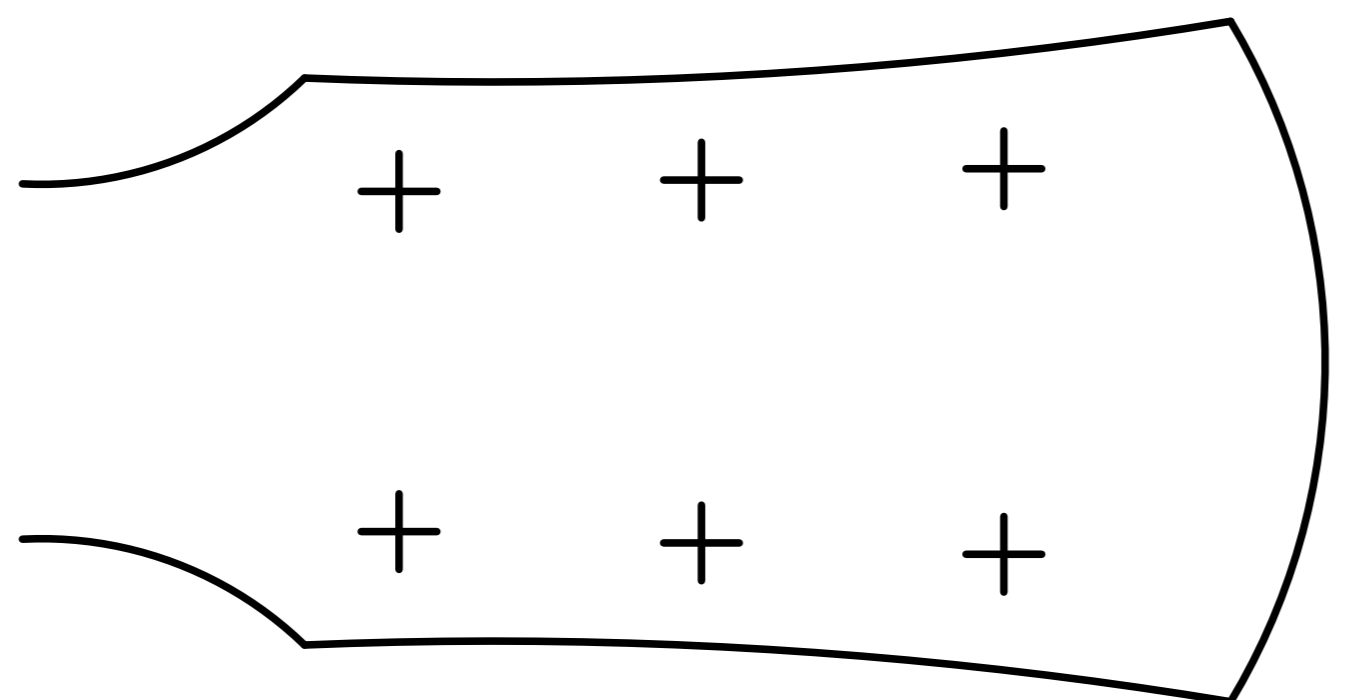

The required drill size will depend on the tuners you have chosen. Start with a small diameter and work up until your tuners just fit through the hole.

Be careful to drill the holes straight, relative to the headstock.

Neck Joint Profile

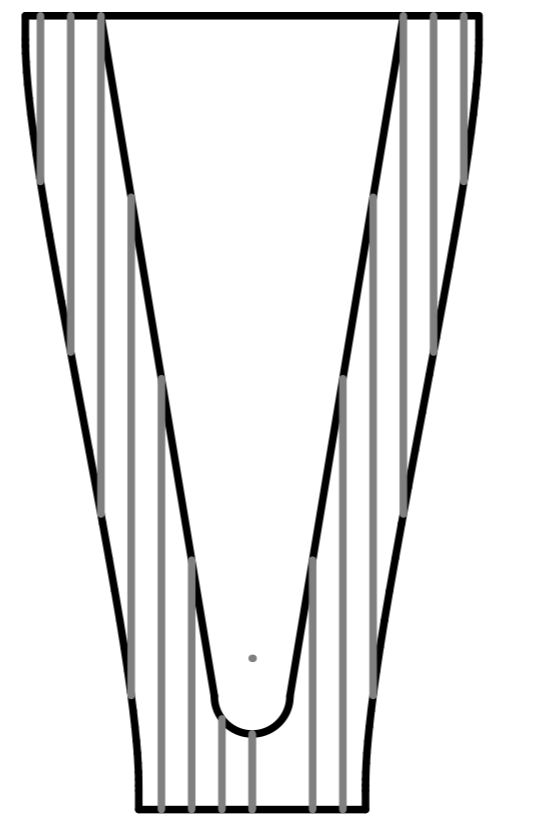

Body Blank

You can cut this out and use it as a template

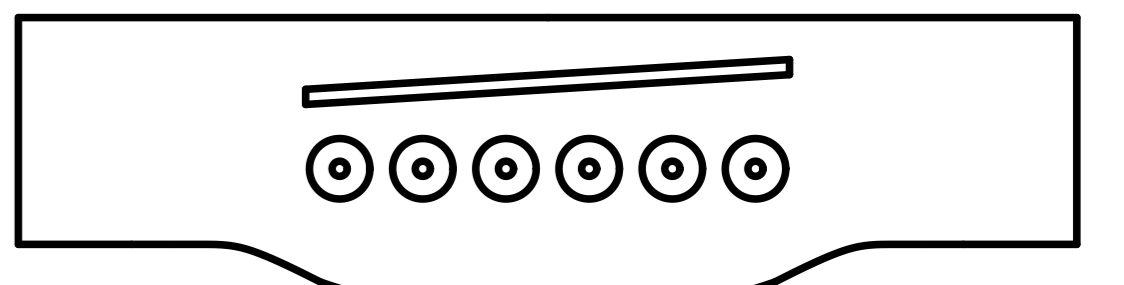
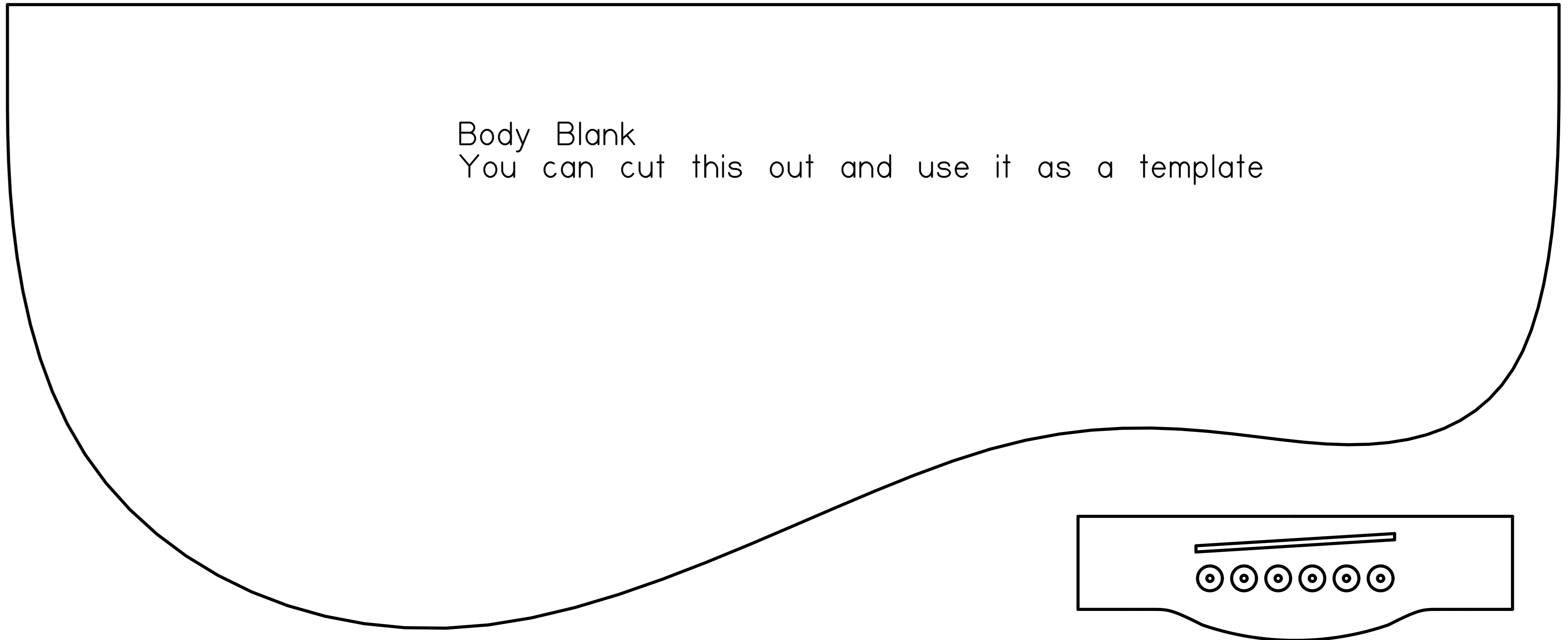

— Outline
 — Dimension
 — Bracing
 — Plate bracing

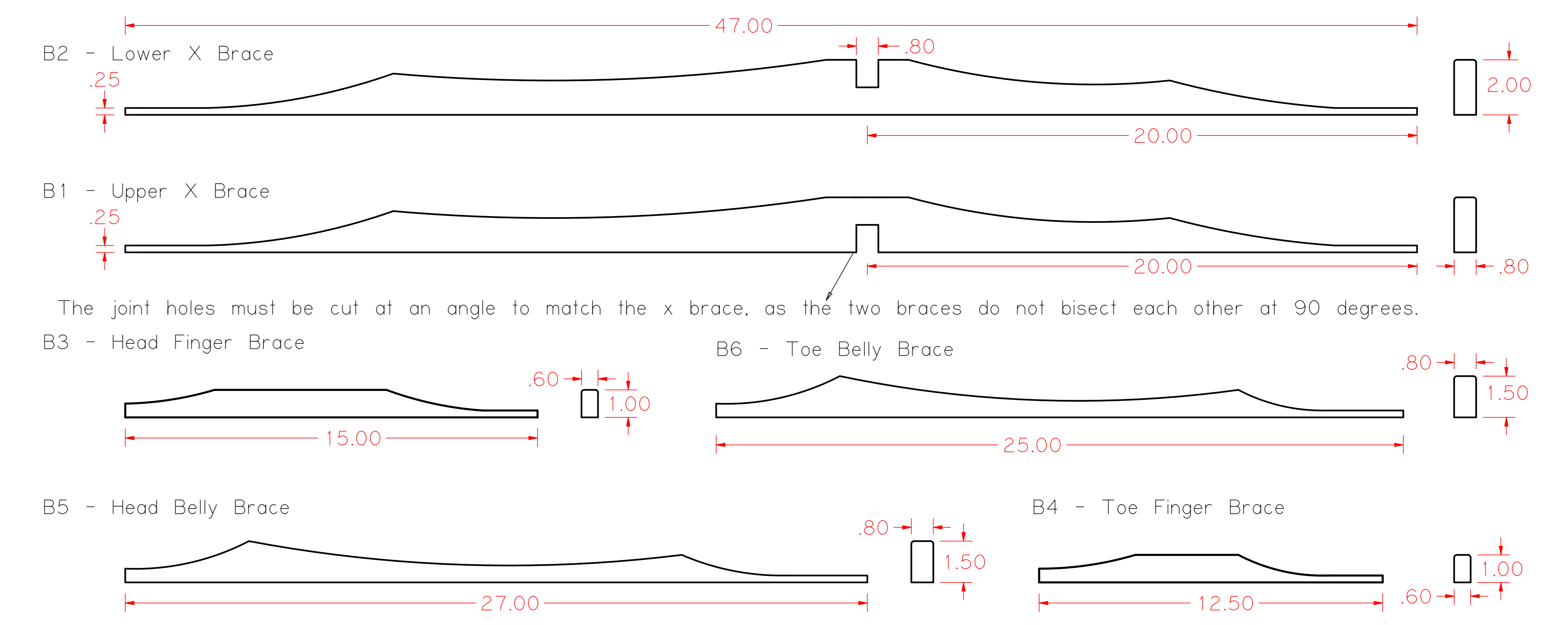
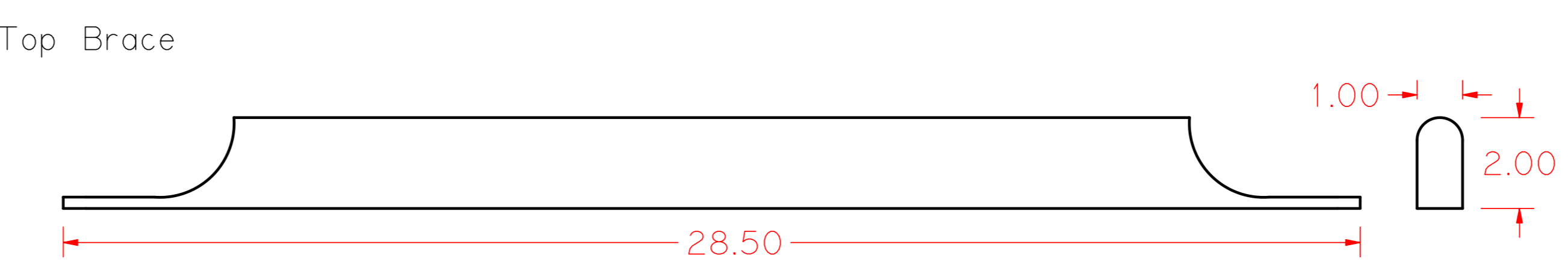
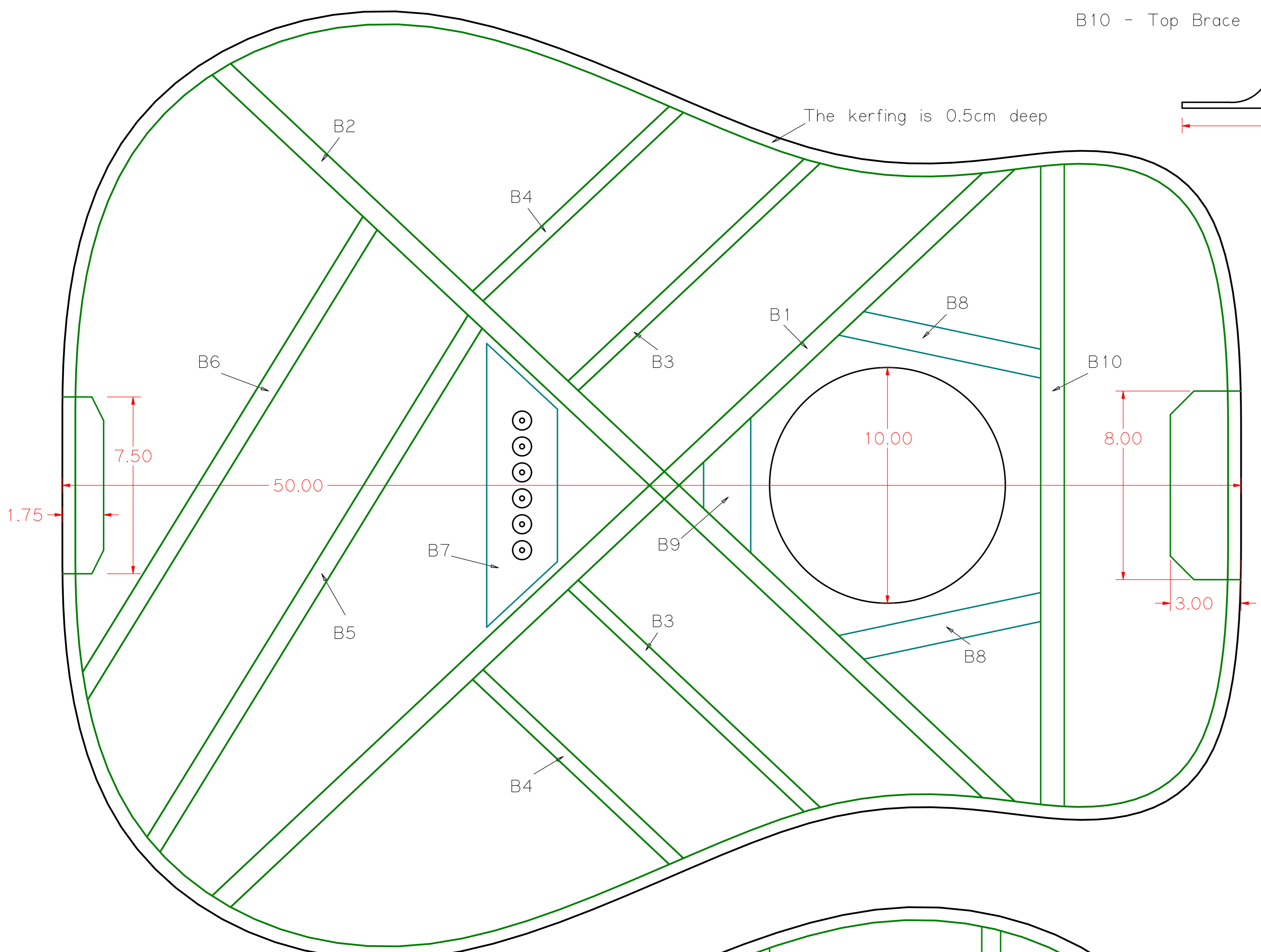

The joint holes must be cut at an angle to match the x brace, as the two braces do not bisect each other at 90 degrees.

Glue the braces to the soundboard over length, such that they extend beyond the edge of the soundboard. All of the braces here are shown over length. Once fixed, trim the length and scallop the braces into the profile shown. Where the braces meet the kerfing, cut shallow gaps into the kerfing such that the soundboard sits flat to the sides. If preferred, trim the finger braces and belly braces just short of the kerfing, so that only the x braces are cut into the kerfing.

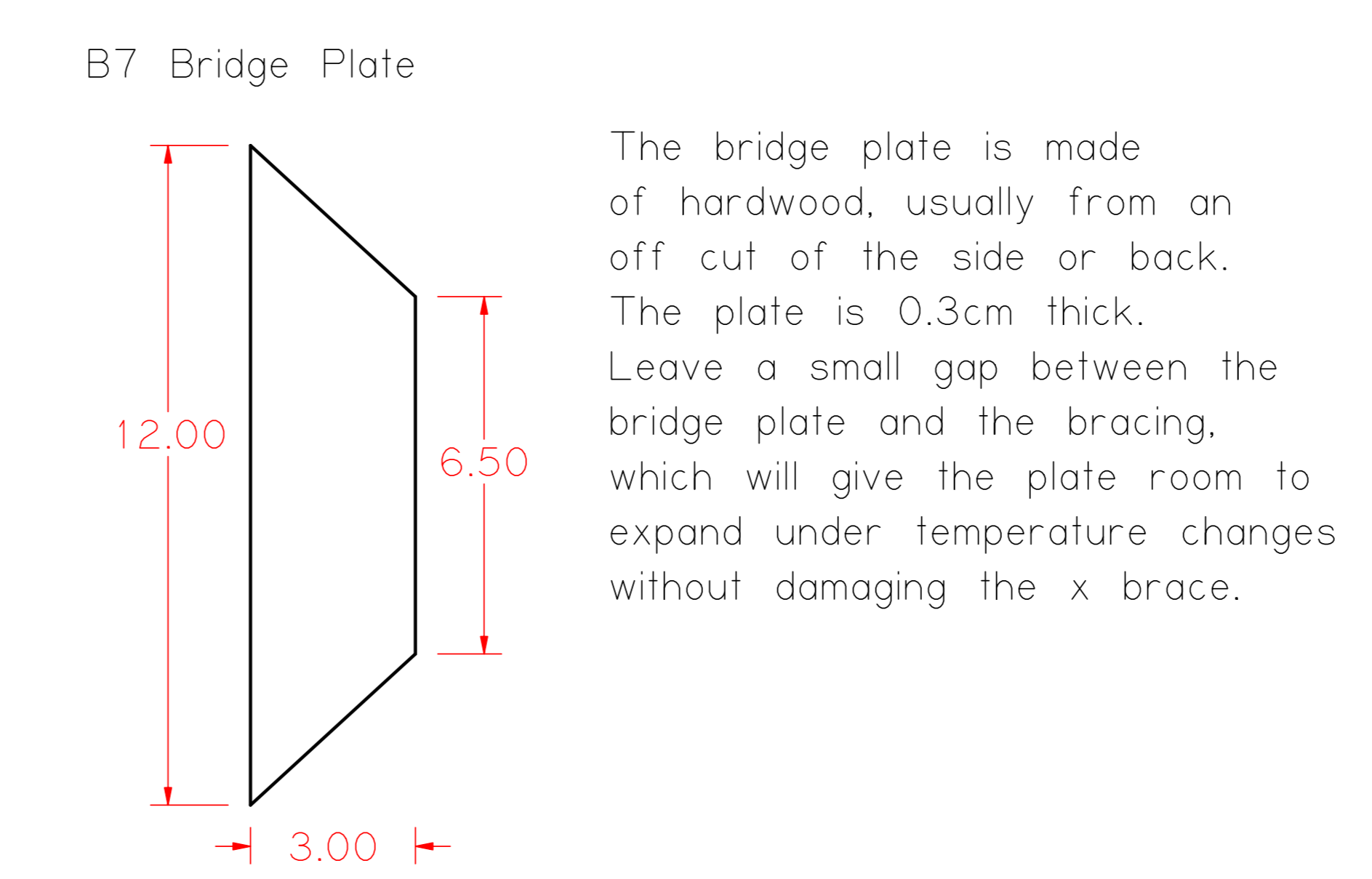
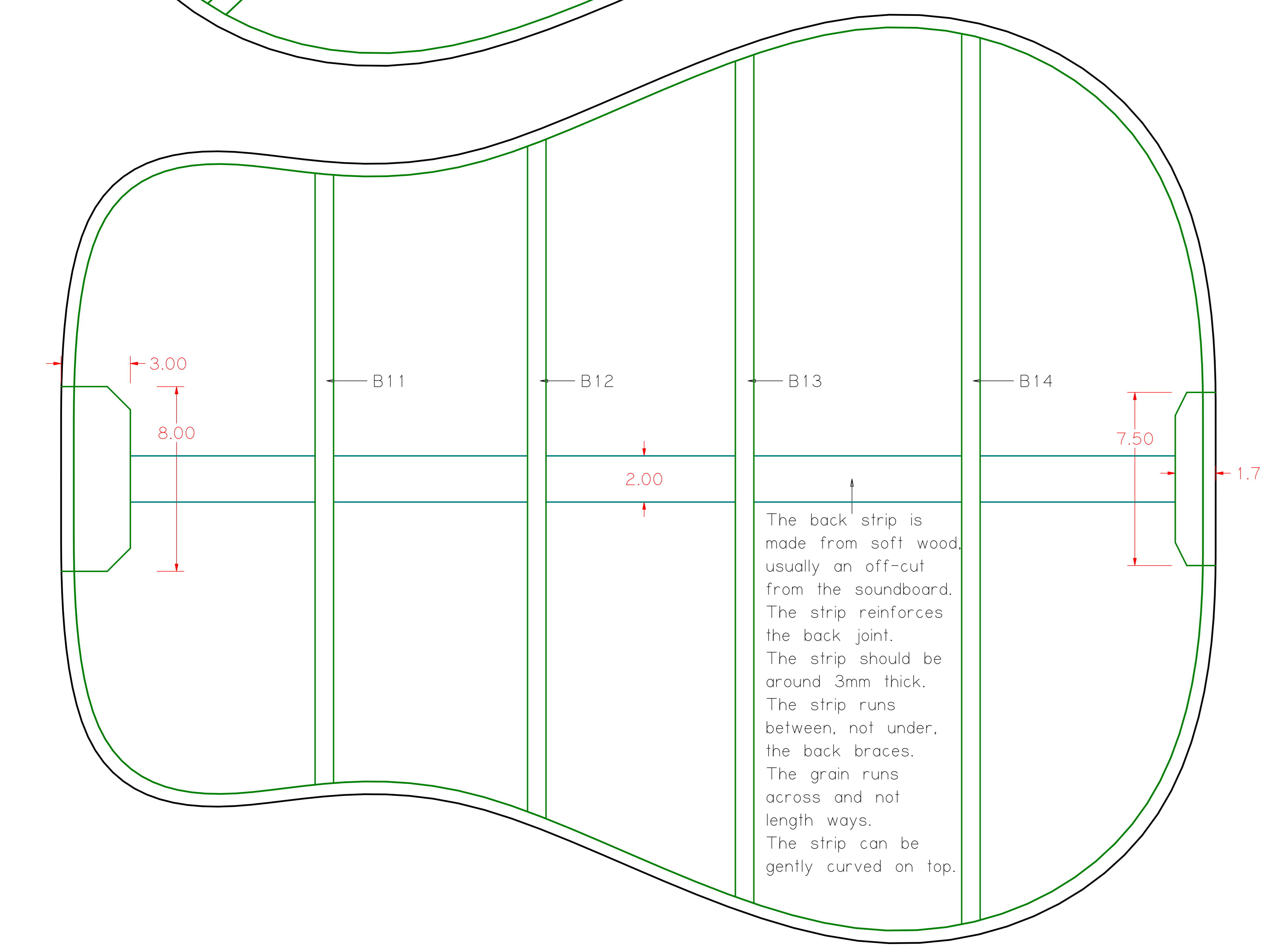

The bridge plate is made of hardwood, usually from an off cut of the side or back. The plate is 0.3cm thick. Leave a small gap between the bridge plate and the bracing, which will give the plate room to expand under temperature changes without damaging the x brace.

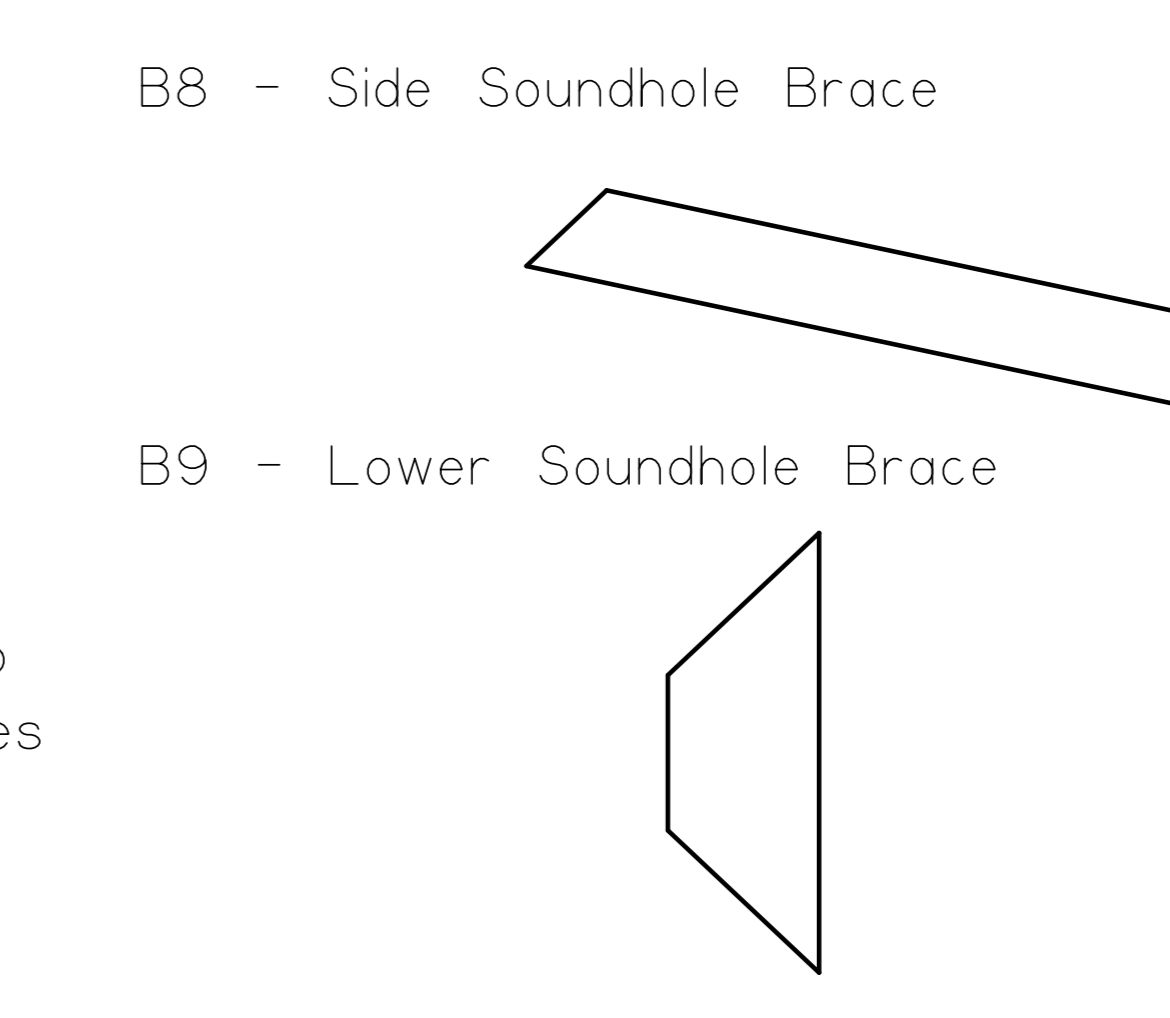

The soundhole bracing is made of softwood, usually an off cut from the soundboard. The soundhole bracing is 0.2cm thick.

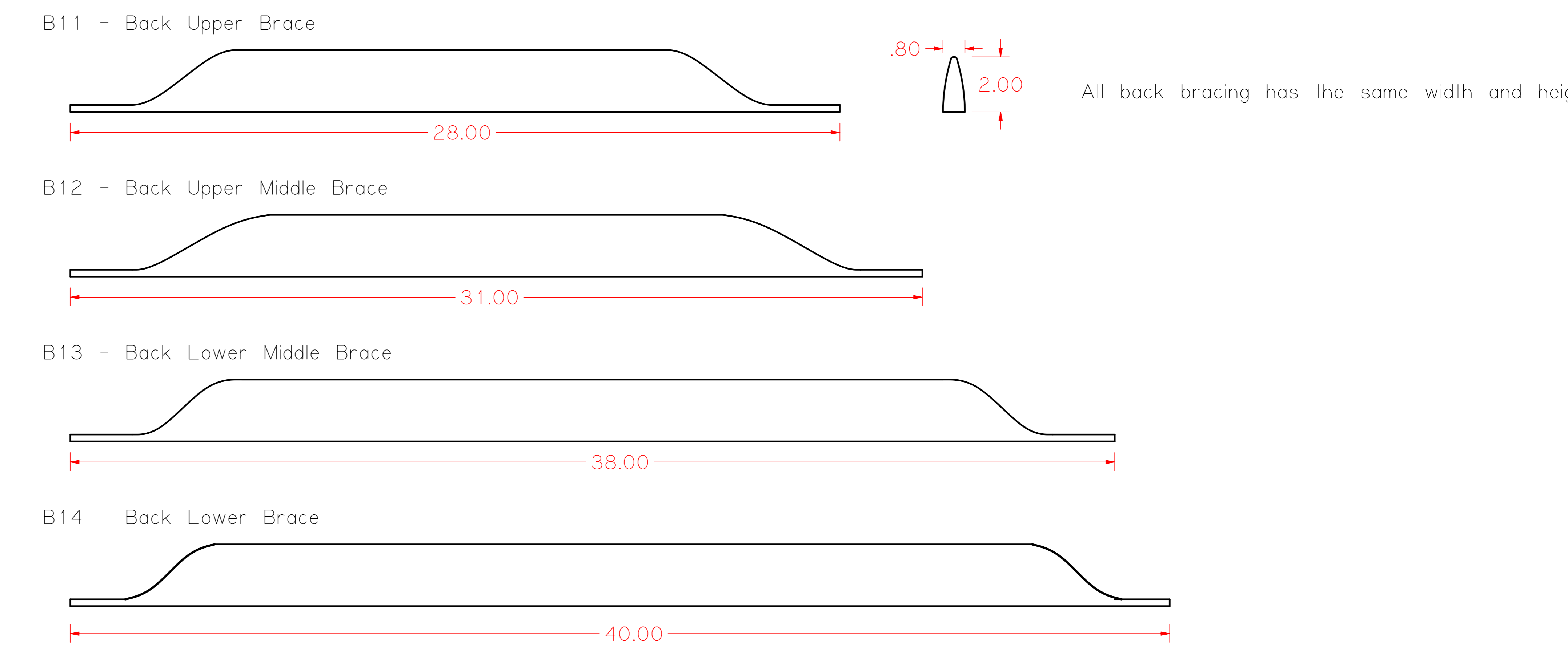

All back bracing has the same width and height